



# Technical Service BULLETIN

February 9, 2007

Title:

## M.I.L. "ON" DTC P0011, P0012, OR P0016

Models:

### '05 – '07 Corolla & Matrix

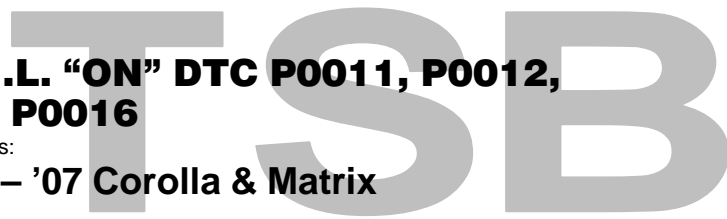

ENGINE  
REVISÉD  
EG005-07

#### TSB REVISION NOTICE:

- March 20, 2007: The times have been updated in the *Warranty Information* table. Previous versions of this TSB should be discarded.

#### Introduction

Under certain conditions, customers may experience a M.I.L. "ON" condition with DTC P0011, P0012, or P0016 stored in the Engine Control Module/ECM (SAE term: Powertrain Control Module/PCM). In some cases, the cause of this DTC may be the VVT-i actuator. Use the procedures in this bulletin to verify the operation of the actuator and correct the condition.

#### Applicable Vehicles

- 2005 – 2007 model year **Corolla** and **Matrix** vehicles produced **BEFORE** the Production Change Effective VINs shown below.

#### Production Change Information

MODEL	ENGINE	PLANT	PRODUCTION CHANGE EFFECTIVE VIN
Corolla	1ZZ-FE	NUMMI	1NXBR3#E#6Z703782
		Takaoka	JTDDBR3#E#60091407
	2ZZ-GE	TMMC	2T1BR3#E#7C733488
			2T1BY3#E#6C552162
Matrix	1ZZ-FE	TMMC	2T1#R3#E#7C634436
	2ZZ-GE		2T1#Y3#E#6C550698

#### Warranty Information

OP CODE	DESCRIPTION	ENGINE	TIME	PLANT	OFF	T1	T2
140021	R & R Camshaft Timing Gear	1ZZ-FE	1.3	All	13050-22012	8A	19
		2ZZ-GE	1.0				
		1ZZ-FE	1.3	NUMMI	13050-0D020		
		2ZZ-GE	1.0	TMMC			

#### Applicable Warranty\*:

This repair is covered under the Toyota Powertrain Warranty. This warranty is in effect for 60 months or 60,000 miles, whichever occurs first, from the vehicle's in-service date.



\* Warranty application is limited to correction of a problem based upon a customer's specific complaint.



**Parts Information**

PREVIOUS PART NUMBER	CURRENT PART NUMBER	PART NAME	QTY
13050-22011	13050-22012	Gear Assembly, Camshaft Timing	1
13050-0D020	Same		1

**Required SSTs**

ITEM NO.	SPECIAL SERVICE TOOLS (SSTs)	PART NUMBER	QTY	DRW**
1	<p><b>Toyota Diagnostic Tester Kit*</b></p> <p>NOTE:</p> <ul style="list-style-type: none"> <li>All components from this kit/set are required.</li> <li>12 Megabyte Diagnostic Tester Program Card (P/N 01002593-005) with version 14.0a Software (or later) is required.</li> </ul> 	TOY220036	1	9
2	<p><b>CAN Interface Module Kit*</b></p> <p>NOTE:</p> <ul style="list-style-type: none"> <li>All components from this kit/set are required.</li> </ul> 	01002744	1	9

\* Essential SSTs.

\*\* Drawer number in SST Storage System.

**NOTE:**

**Additional Diagnostic Tester Kits, CAN Interface Modules, Program Cards, or other SSTs may be ordered by calling SPX/OTC at 1-800-933-8335.**

**Repair Procedure**

1. Referring to the screen flow in Figure 1 below, connect the Toyota Diagnostic Tester to the vehicle and select the VVT Control Bank 1 Active Test (VVT CTRL B1) from the Active Test Menu.

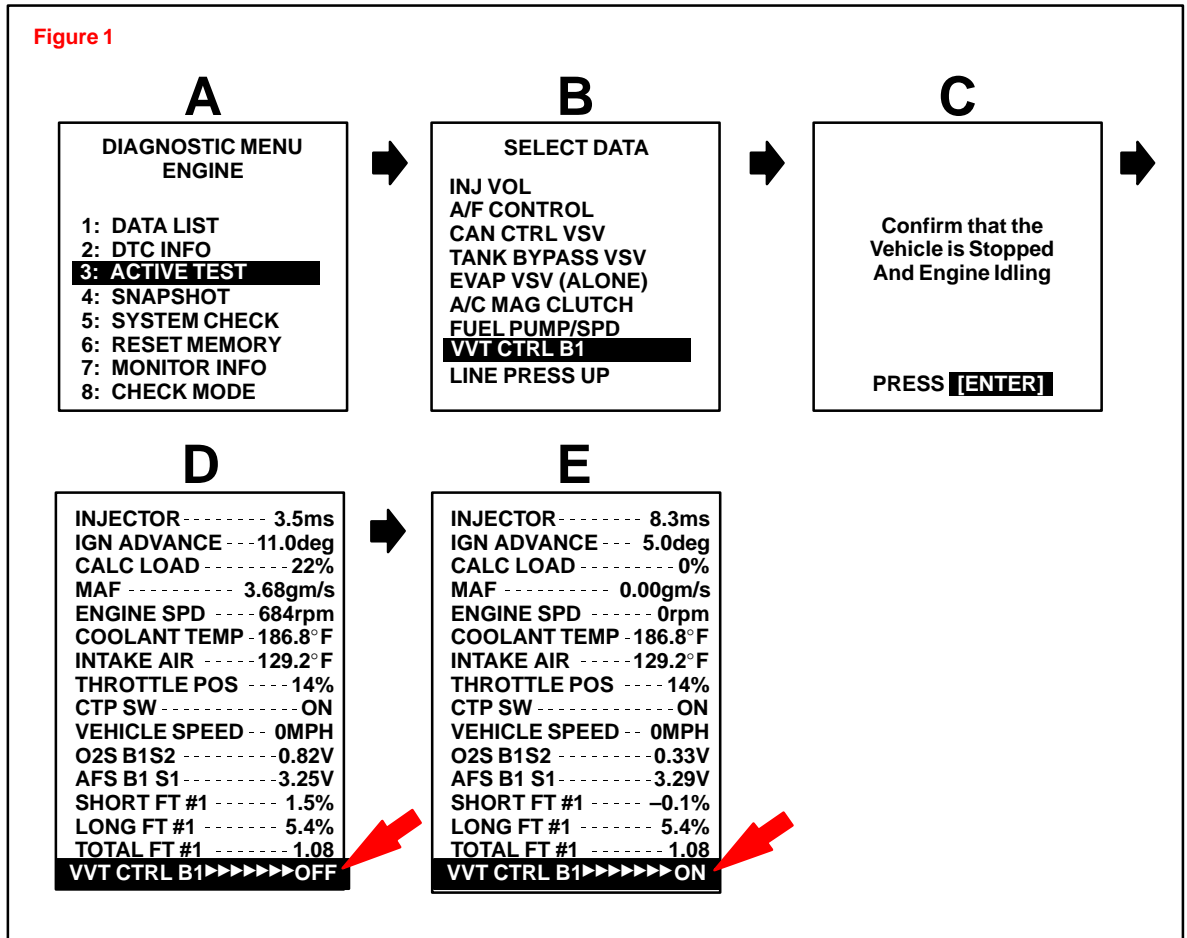

2. Using the right arrow key, toggle the VVT actuator "ON".
3. Does the engine run rough and/or stall?  
**YES:** Proceed to step 4.  
**NO:** Check the oil control valve operation.  
 Refer to the Technical Information System (TIS):
  - 2005 model year Corolla or Matrix Repair Manual, *Engine/Hybrid System – Engine Control – "1ZZ-FE / 2ZZ-GE: SFI System: Inspection"*
  - 2006 – 2007 model year Corolla or Matrix Repair Manual, *Engine/Hybrid System – Engine Control – "1ZZ-FE / 2ZZ-GE: Engine Control System: Camshaft Timing Oil Control Valve Assembly: Inspection"*

**Repair Procedure**  
(Continued)

4. Remove and replace the camshaft timing gear assembly.

Refer to TIS:

- 2005 model year Corolla or Matrix Repair Manual, *Engine/Hybrid System – Engine Mechanical – "1ZZ-FE / 2ZZ-GE: Camshaft: Replacement"*
- 2006 – 2007 model year Corolla or Matrix Repair Manual, *Engine/Hybrid System – Engine Mechanical – "1ZZ-FE / 2ZZ-GE: Engine Mechanical: Camshaft: Removal"*

**NOTE:**

The timing gear **MUST** be in the unlocked position when installing on the camshaft. Please see step 5 for instructions to unlock the camshaft timing gear.

5. Identify whether the camshaft timing gear is unlocked or locked. (See Figure 2.)

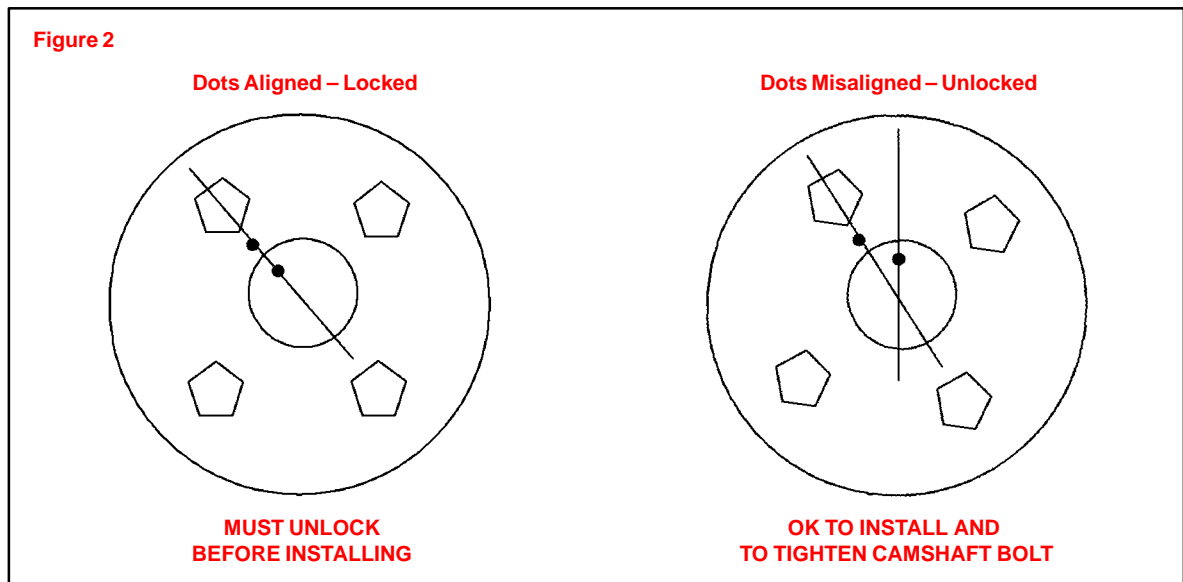

- If the camshaft timing gear is unlocked, it is ready to install.
- If it is **LOCKED**, follow the steps below to unlock the camshaft timing gear **before** installing.

- A. To disengage the camshaft timing gear lock pin, apply and hold approximately 21 psi of air pressure at the oil feed hole located 90 degrees clockwise of the oval slot. (See Figure 3.)

**NOTE:**

The lock pin is inside the gear, **NOT** the one located in the oval slot.

- B. With the 21 psi of air still applied to the gear, turn the interior assembly counterclockwise. (See black arrow in Figure 3.)

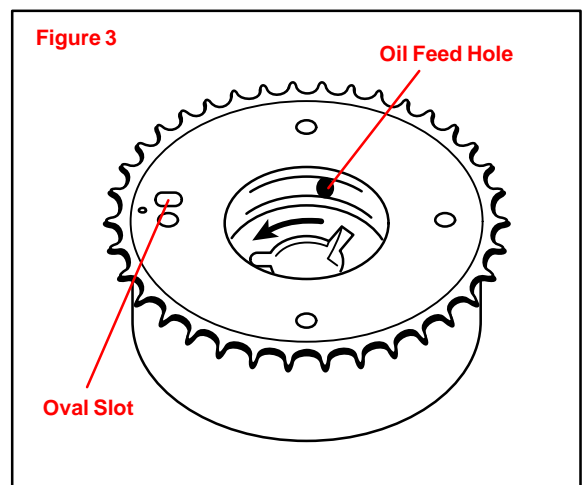

**Repair Procedure**  
(Continued)

- C. Install the timing gear assembly onto the camshaft with the straight pin slightly to the right of the key groove as shown in Figure 4.
- D. Turn the camshaft timing gear assembly while pushing it lightly against the camshaft until the straight pin engages the key slot.
- E. Check that the camshaft timing gear is fully seated on the camshaft and that there is no clearance between the end of the camshaft and the timing gear. Install the camshaft bolt finger tight.

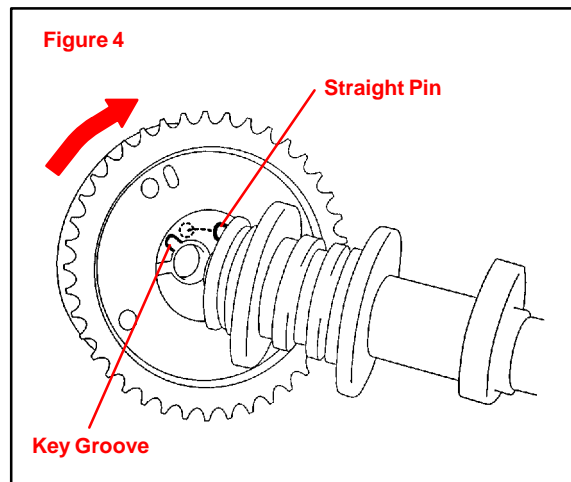

**NOTE:**

Check to make sure that the camshaft timing gear is still unlocked **BEFORE** tightening the camshaft bolt. The lock pin **MUST** be unlocked to prevent damage to the camshaft timing gear lock pin during tightening.

**Dots Misaligned – Unlocked**

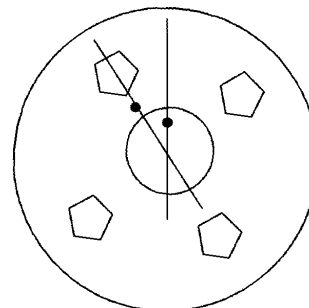

**OK TO INSTALL AND TO TIGHTEN CAMSHAFT BOLT**

- F. While holding the camshaft with a wrench, tighten the camshaft bolt.

**Torque: 54 N•m (551 kgf•cm, 40 ft•lbf)**

**Repair  
Procedure**  
(Continued)

- G. After torquing the camshaft bolt, rotate the camshaft timing gear in a clockwise direction while holding the camshaft stationary until the dots are aligned, thereby engaging the camshaft timing gear lock pin.

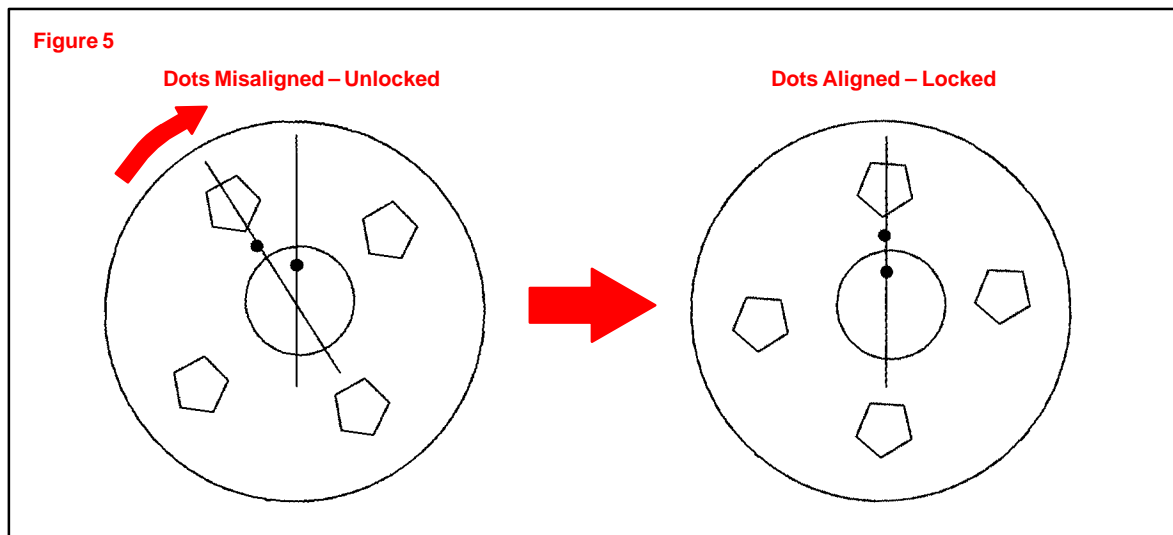

- H. The timing gear is now ready for installation of the timing chain.

**NOTE:**

Camshaft timing is performed with the camshaft timing gear in the locked position (dots aligned).